



ALAIN RACEWAY

UAE ROTAX MAX CHALLENGE 2012-13 Organised by AL AIN RACEWAY KART CLUB

In Association With



SERIES TECHNICAL REGULATIONS VERSION 01.09.12

REGULATIONS

The final text of these Technical Regulations shall be the English version, which will be used, should any dispute arise as to their interpretation. Headings in this document are for ease of reference only and do not form part of the regulations.

1 - CATEGORIES

Karts used in the UAE RMC Championship are divided into the following groups:

- ROTAX 125 Micro MAX * (cylinder capacity 125 cc)
- ROTAX 125 Mini MAX * (cylinder capacity 125 cc)
- ROTAX 125 Junior MAX (cylinder capacity 125 cc)
- ROTAX 125 MAX/MASTERS (cylinder capacity 125 cc)
- ROTAX 125 MAX DD2/MASTERS (cylinder capacity 125 cc, 2-speed)

* For ROTAX 125 Mini MAX and 125 Micro MAX please see Appendix

2 - AMOUNT OF EQUIPMENT

For each race event (from non-qualifying practice to the Final), the maximum amount of equipment is:

- 1 chassis
- 2 sets of dry tyres (total 4 front tyres plus 4 rear tyres)
- 2 engines

3 - KART

3.1 Chassis

For UAE RMC Championship any CIK homologated chassis (according to Article 2.3 of the CIK technical Regulations) is allowed, subject to the following criteria:

125 Micro MAX

Wheel base: min 850mm, max 950mm (± 5 mm)
Diameter of main tubes 28mm, round tubing only
Maximum overall width 1200mm
No front wheel hubs permitted
Rear axle: 25mm solid or 30mm hollow, minimum wall thickness according to CIK
Brake system must work on rear wheels only and have a valid CIK-FIA homologation

- CORPORATE EVENTS
- PRIVATE EVENTS
- ARRIVE AND DRIVE
- JUNIOR RACING
- RACE SCHOOL
- PRIVATE TUITION
- EVENT MANAGEMENT
- CONFERENCING
- RESTAURANT
- KART SHOP
- ARKS TESTING
- ACCESSORIES
- SERVICE CENTRE
- CONSULTANCY

AUTHORISED DISTRIBUTOR
ROTAX
KART PRODUCTS



✉ P.O.Box 85393. Al Ain. UAE.

☎ +971 (0) 3 768 6662

📠 +971 (0) 3 768 8477

@ sales@alainraceway.com

🌐 www.alainraceway.com

125 Mini MAX

Wheel base: 950mm (± 5 mm)
 Diameter of main tubes 28mm, round tubing only
 Maximum overall width 1200mm
 No front wheel hubs permitted
 Rear axle: 25mm solid or 30mm hollow, minimum wall thickness according to CIK
 Brake system must work on rear wheels only and have a valid CIK-FIA homologation

125 Junior MAX and 125 MAX classes

Maximum diameter of chassis tubing = 32 mm, round tubing only
 Maximum diameter of rear axle = 50 mm, minimum wall thickness according to CIK
 Any brake system must have a valid CIK-FIA homologation
 Front brakes are not allowed in the 125 MAX Junior MAX class
 Front brakes are allowed in 125 MAX and MAX Master classes

125 MAX DD2 class

Chassis must be designed according to CIK-FIA rules for shifter classes (front and rear brakes mandatory).
 Any brake system must have a valid CIK-FIA homologation.
 ROTAX Rear Tyre Protection System is mandatory to be used. Either old 2 tube version or latest 3 tube version (third tube can be mounted above or below the 2 main tubes). No part shall be added or removed from original content.

3.2 Bodywork

In accordance with CIK-FIA regulations

4 – TYRES

The permitted tyres for each class are detailed below.
 Strictly no modifications or tyre treatment are allowed.
 The marked direction of rotation must be adhered to at all times.

4.1 Dry tyres:

125 Micro MAX	MOJO C2	Front 4.0 x 10.0 - 5	Rear 5.0 x 11.0 - 5
125 Mini MAX	MOJO C2	Front 4.0 x 10.0 - 5	Rear 5.0 x 11.0 - 5
125 Junior MAX	MOJO D1	Front 4.5 x 10.0 - 5	Rear 7.1 x 11.0 - 5
125 MAX/Master	MOJO D2	Front 4.5 x 10.0 - 5	Rear 7.1 x 11.0 - 5
125 MAX DD2	MOJO D3	Front 4.5 x 10.0 - 5	Rear 7.1 x 11.0 - 5

4.2 Wet tyres:

All classes N/A

5 – DATA ACQUISITION

This system, with or without a memory, may permit only (i) the reading/recording of the engine revs (by induction on the sparkplug HT cable), (ii) two indications of temperature, (iii) the speed of one wheel, (iv) X/Y acceleration, (v) lap times and (vi) position (via GPS system).

6 – COMPOSITE MATERIALS

Composite materials (carbon fibre, etc.) are banned except for the seat, floor tray and brake disc. Alloys from different metals are not considered composite materials.

7 – SAFETY EQUIPMENT

Race suit, helmet, kart boots, gloves and other items of driver protection must comply with Article 3 of the CIK Technical Regulations (see also UAE RMC Sporting Regulations 2012-13).

8 – PETROL/OIL

Petrol: unleaded commercial quality from petrol station, 95-98 octane.
 Oil: XPS-Kart Tec 2-stroke oil (CIK homologation no. 109322/01) or Kart Care Combat TMAX oil.



9 – ENGINES

Only engines which have been checked and sealed by Al Ain Raceway (UAE ROTAX Distributor) or one of their official authorised Service Centres are allowed to be used.

By sealing an engine Al Ain Raceway (and their Service Centres) take over the responsibility for the conformity of the engine according to the valid Technical Specification. A brand new engine is always checked according to the Technical Specification before sealing.

The engines must be sealed with specific ROTAX engine seals (black anodised aluminium seal with "ROTAX "logo and a 6 digit serial number [and bar code for new seals] - see attached picture).



By means of the steel cable the engine must be sealed on one Allen screw (1) of the intake flange, on one stud screw (2) of cylinder and one Allen screw (3) of the cylinder head cover (see right picture).



It is not allowed to pass the end of the sealing wire through the seal a second time (only as in above picture).

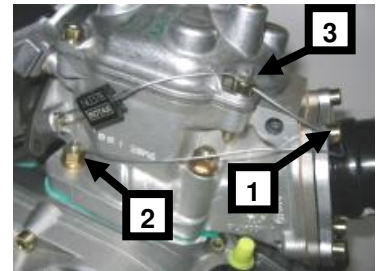

After sealing the engine seal thread must be squeezed using ROTAX calliper 276110 (see left picture).

At every new sealing of an engine Al Ain Raceway (or their Service Centres) is responsible for following amendments of the Engine Identity Card which belongs to the owner of the engine:

- Serial no. of the engine
- Serial no. of the engine seal
- Stamp and signature of the Company to be able to detect at Scrutineering which authority has checked and sealed the engine.

At Scrutineering the driver must present:

- the engine(s) with undamaged engine seal(s)
- the Engine Identity Card(s) showing the matching engine serial no.(s), the matching engine seal no.(s) and the stamp(s) and signature(s) of the authority that has checked and sealed the engine(s).

The sealing of engines helps to reduce the times for Scrutineering at races as during the race event only the accessories (carburettor, exhaust, radiator.....) need to be checked.

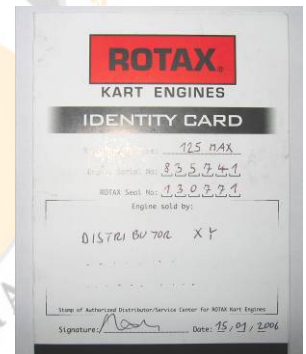

Of course, Scrutineers can request to open and re-check an engine according to the Technical Specification before or after a race or in case of a protest. If an engine seal has been broken (for whatever reason), the engine must be checked completely for compliance according to the Technical Specification. Re-sealing may only then be carried out at the discretion of Al Ain Raceway. If Al Ain Raceway suspects that an engine has been tampered with in any way, that engine will be excluded from competition and will not be resealed under any circumstances.

Only genuine ROTAX components that are specifically designed and supplied for the 125 Micro MAX, 125 Mini MAX, 125 Junior MAX, 125 MAX and 125 MAX DD2 engine are legal, unless otherwise specified.

Neither the engine nor any of its ancillaries may be modified in any way. "Modified" is defined as any change in form, content or function that represents a condition of difference from that originally designed. This is to include the addition and/or omission of parts and/or material from the engine package assembly unless specifically allowed within these rules. The adjustment of elements specifically designed for that purpose shall not be classified as modifications, i.e. carburettor and exhaust valve adjustment screws.

ANYTHING WHICH IS NOT EXPRESSLY ALLOWED IN THE TECHNICAL REGULATIONS IS FORBIDDEN.

Internal additions:

No additional material may be added except in the case of engine repairs and shall only restore the engine or components to original specifications.
The use of thermal barrier coatings/ceramic coatings on or in the engine and on or in the exhaust system is prohibited.
The use of anti-friction coatings in or on the engine/engine components is prohibited.
Customising the cylinder head cover by painting is prohibited.

Legal additions:

Chain guard, engine mount, temperature gauge and tachometer/hour meter, inline fuel filter, catch-can mounting brackets and supplemental ignition coil mounting brackets, within the limits specified in these regulations.

Non-tech items:

Non-original fasteners, circlips, washers, electrical mass cable, throttle cable housing, fuel and pulse line (type and size) as well as lengths of coolant hose are allowed unless otherwise specified.

Note:

When taking any dimensional reading of the following technical regulations, in the order of accuracy of 0.1 mm (or even more precise), the temperature of the part must be between +10°C and +30°C.

To avoid excessive noise and exhaust emissions revving the engine in the servicing park is not permitted (except in the case of a short function test).

It is the responsibility of the competitor to check his/her equipment (all components outside the engine seal and mentioned below), to assure that his/her equipment is in line with all technical specifications!

10 - TECHNICAL SPECIFICATION (WITHIN ENGINE SEAL) FOR ROTAX KART ENGINES 125 JUNIOR MAX (15 kW) AND 125 MAX (21 kW)

Please note that for engine configuration 125 Micro MAX and 125 Mini MAX, the technical specification of 125 Junior MAX is valid for anything unspecified in the Appendix.

10.1 Squish Gap

The squish gap must be measured with a certified slide gauge and by using a 2 mm tin wire. The crankshaft must be turned by hand slowly over TDC (top dead centre) to squeeze the tin wire.

The squish gap must be measured on the left and right side in the direction of the piston pin. The average value of the two measurements counts.

Recommended 2mm tin wire (580 130)

10.1.1 125 Junior MAX 1.20 - 1.80 mm

10.1.2 125 MAX 1.00 - 1.50 mm



10.2 Combustion Chamber Insert

10.2.1 Cast identification code must be "223 389," "223 389 1," "223 389 2" or "223 389 2/1"

10.2.2 Cast wording "ROTAX" and/or "MADE IN AUSTRIA" must be shown.



10.2.3 Heights of combustion chamber insert must be 27.55 mm with a tolerance of +0.0/-0.1 mm (A) and 28.80 mm with a tolerance of +/- 0.2 mm (B)

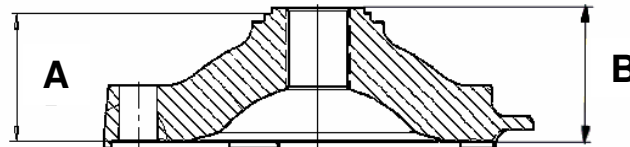

10.2.4 The profile of the combustion chamber insert has to be checked with a template (ROTAX part no. 277 390).

The crack of light between the template and the profile of the combustion chamber insert has to be the same over the whole profile.

NOTE: This check is just for reference. In case of doubt detailed measurements must be performed to define conformity or non-conformity.



10.3 Piston with ring assembly

10.3.1 Original, coated or uncoated, aluminium, cast piston with one piston ring. The piston has to show on the inside the cast wording "ELKO" (1) and "MADE IN AUSTRIA" (2).

10.3.2 Machined areas are: top end of piston, outside diameter, groove for the piston ring, bore for the piston pin, inside diameter at bottom end of piston and some pre-existing factory removal (3) of flashing at the cut out of the piston skirt. All other surfaces are not machined and have cast surface.

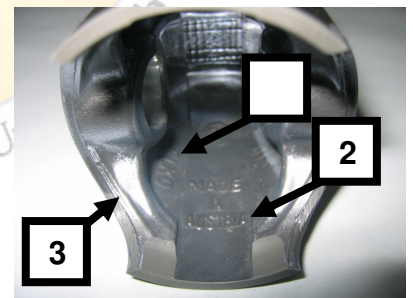

10.3.3 Original, magnetic, rectangular piston ring.

Ring height: 1 -0.01 / -0.025 mm.

Piston ring is marked either with "E CRY K" or "ROTAX 215 547" or "ROTAX 215 548".



10.4 Gudgeon pin

- 10.4.1 Gudgeon pin is made out of magnetic steel.
- 10.4.2 Dimensions must be according to the drawing.
- 10.4.3 The minimum weight of the gudgeon pin must not be lower than 32.10g

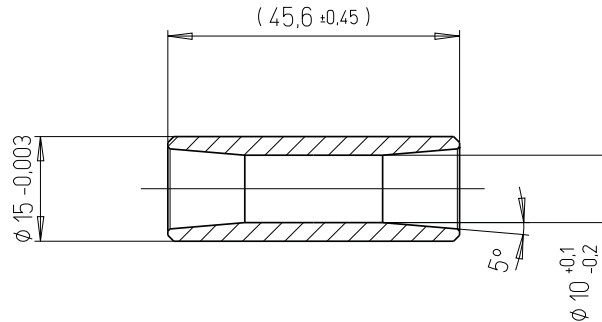

10.5 Cylinder

- 10.5.1 Light-alloy-cylinder with GILNISIL-plating. Any re-plating of cylinder is not allowed.
- 10.5.2 Cylinder with one main exhaust port.
- 10.5.3 Maximum bore of cylinder = 54.035mm (measured 10mm above exhaust port)
- 10.5.4 Cylinder has to be marked with the "ROTAX" logo (see pictures below).

10.5.5.1 125 Junior MAX, 125 Mini MAX and 125 Micro MAX

Cylinder without pneumatic timed exhaust valve. Cylinder must be marked either with identification code 223 999, 223 998 or 223 994.



10.5.5.2 125 MAX

Cylinder with pneumatic timed exhaust valve. Cylinder must be marked either with identification code 223 997, 223 996 or 223 993.



- 10.5.6 Height of cylinder must be 87mm -0.05/+0.1mm.

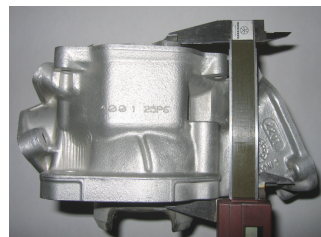

10.5.7.1 All transfer ports and passages have cast finish surface except some removal (done by the manufacturer) of cast burr at the inlet passage and exhaust port and passages. All ports have chamfered edges to prevent ring snagging. Any additional machining is not permitted. The top edge of exhaust port may show some pre-existing machining from the manufacturer. The sealing flange for the exhaust socket may show signs of machining from the manufacturer.

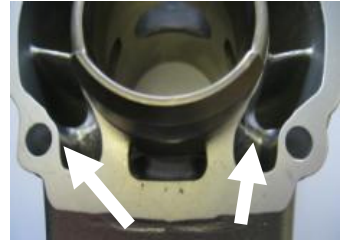

10.5.7.2 All ports have chamfered edges (see right picture). Any additional machining is not permitted.



On cylinders marked 223993 and 223994 the upper edge of the central boost port may show factory machining (see left picture)

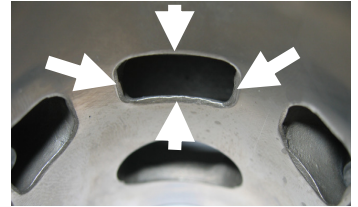

10.5.7.3 The sealing flange for the exhaust socket may show either cast finish surface or signs of machining from the manufacturer.

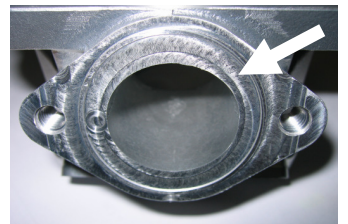

10.5.7.4 The top edge of the exhaust port may show either just a cast finish surface (below left picture) or signs of a CNC machining (below centre picture) or signs of CNC machining in combination with signs of manual grinding (below right picture).

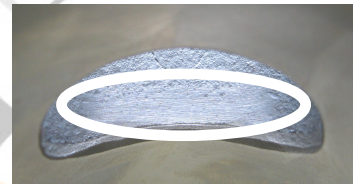
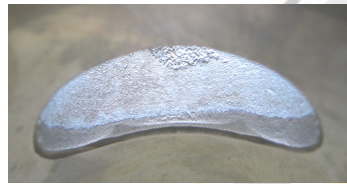

The exhaust port may show partial manual grinding done by the manufacturer to eliminate minor casting defects and to eliminate the NIKASIL burr at the end of the NIKASIL plating.

The exhaust ports of cylinders 223993 & 223994 may show factory machining all around.



10.5.8 The "exhaust port timing" (distance from the top of the cylinder to the top of the exhaust port) must be checked by means of the template (ROTAX part 277397).

Insert the template into the cylinder so that the template is touching the cylinder wall and the finger of the template is located in the middle of the exhaust port (highest point).

Move the template upwards until the finger is touching the top edge of the exhaust port. Insert a feeler gauge between the top of the cylinder and the template. It MUST NOT be possible to fit the feeler gauge specified below:



125 Junior MAX: 0.90 mm for cylinder 223999/998

125 Junior MAX: 1.10mm for cylinder 223994

125 MAX: 0.75 mm

For cylinder 223993 (125 MAX) it is also legal if the template does not fit in at all.

NOTE: Take care to use the corresponding gauge of the template (Junior or MAX) for the respective cylinder!

10.5.9 Exhaust Valve (125 MAX only)

If the piston is moved to the top of the cylinder until it completely covers the exhaust port, it must be possible to insert the exhaust valve gauge (ROTAX part 277030) until it stops at the surface of the cylinder (a feeler gauge of 0.05 mm must not be possible to fit in)

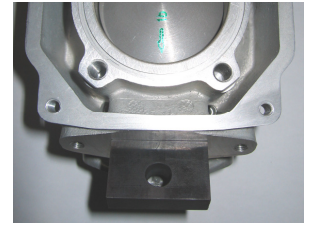

10.6 Inlet System

10.6.1 Inlet manifold is marked with the name "ROTAX" and the identification code "267 915".

10.6.2 Some factory flash removal may be present at the conjunction of the inside contour and the carburettor stop mounting face. This is a manual trimming operation consisting of a small corner break of less than 3 mm in width. No additional grinding or machining is permitted.

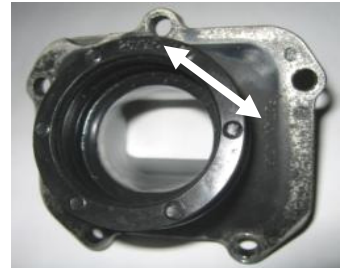

10.6.3 The reed valve assembly is equipped with 2 petal stops and 2 reeds, each having 3 petals.

10.6.4 The thickness of the reeds is 0.6 mm +/- 0.10 mm.

10.7 Crankshaft

10.7.1 Stroke 54.5 mm +/-0.1 mm

10.7.2 Con rod has to show forged numbers "213", "365" or "367" on shaft.

10.7.3 Shaft of con rod is not machined (copper plated). Grinding or polishing of shaft of con rod is not permitted.

10.7.4 Crankshaft main bearing 6206 from FAG only is allowed (must be marked with code 579165BA or Z-579165.11.KL)

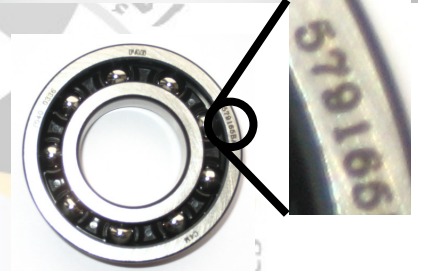

10.8 Balance shaft

10.8.1 Balance shaft and balance gears must be installed.

10.8.2 Different configurations of part 237945 and 237949 (or 237948) are legal.

Please note that 237945 will not be permitted from May 2013 onwards.

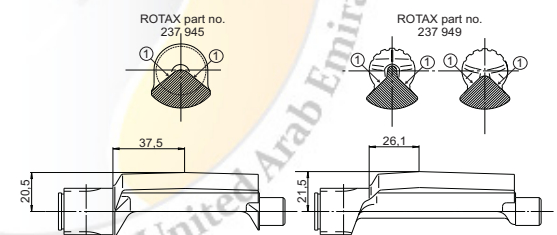

10.8.3 Surface (1) is not machined and must show cast surface.

10.8.4 Measurement from centre of balance shaft to outer diameter of fly weight of balance shaft at defined length must not be lower than specified.

10.8.5 The minimum weight of the dry balance shaft must not be lower than 355g for balance shaft 237945 and 255g for balance shaft 237949 (237948).

10.9 Crankcase

As supplied by the manufacturer. No grinding/polishing is permitted in the two main transfer passages as well as in the crank area.

11 – TECHNICAL SPECIFICATION (OUTSIDE ENGINE SEAL) FOR ROTAX KART ENGINES 125 JUNIOR MAX (15 kW) AND 125 MAX (21 kW)

It is the responsibility of the competitor to check all components outside the engine seal to ensure that they are in line with the technical specifications below.

Please note that for engine configuration 125 Micro MAX and 125 Mini MAX, the technical specification of 125 Junior MAX is valid for anything unspecified in the Appendix.

11.1 Balance Drive

Balance gears must be installed and aligned according to the instruction in the repair manual.

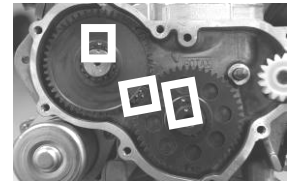
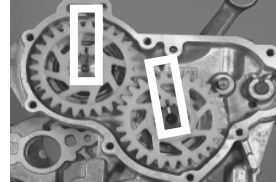

11.1.1 Old version "plastic" balance gears can only be used with old type centrifugal clutch (left picture).

11.1.2 Newer version "steel" balance gears can be used with old AND new type centrifugal clutches (right picture).

Mixing of steel balance gears of different width (6.0 mm and 9.0 mm) is strictly forbidden.

11.2 Ignition System

11.2.1 DENSO digital battery ignition, variable ignition timing, no adjustment necessary and possible.

Race officials may request at any time that the competitor replace the ignition coil with a new unit provided by the race administration.

11.2.2 The casting of the ignition coil has to show the following in casting "129000-" and "DENSO".

11.2.3 Ignition coil must show 3 pins at the terminal.

11.2.4 Connector housing of ignition coil must have either black or green colour. Ignition coils 265572 & 265578 are permitted. 265571 (assembly) is not permitted.

11.2.5 The ignition coil has to be fixed by means of 2 original silent blocks to the gearbox cover. Only in case of chassis component interference with the original mounting location of the ignition coil, a supplementary extension bracket, rigidly constructed and fabricated of solid metal, of minimum dimensions and attached to the original case mounting holes, is permitted for mounting of the coil.

11.2.6 The minimum length of ignition wire (high tension wire) is 210 mm from outlet of cable at ignition coil to outlet of cable at spark plug connector (= the visible length of wire). Ignition coil must be in working condition (to be tested in case of doubt).

11.2.7 The pick-up must be marked with the numbers 029600-0710, followed by a variable production code in the 2nd line.

HINT: In case of doubt an easy check is to place a steel ball (3-5 mm in diameter) on the pick-up (engine side). The steel ball must stay in the centre of the pickup surface.

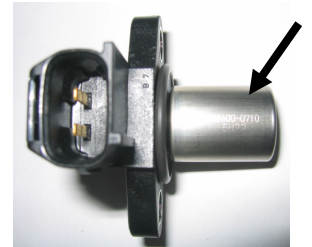

11.2.8 Spark plug: DENSO Iridium IW 27 or 29 or 31

11.2.9 Spark plug cap must be marked with "NGK TB05EMA".

11.2.10 Original battery must be used:

YUASA YT7B-BS or **ROTAX** RX7-12B or **ROTAX** RX7-12L (lithium iron phosphate)

11.2.11 Battery must be fitted with the original battery clamp and battery cover (see illustration below) and must be fixed to the chassis with at least 2 screws. Position of the battery is free.

11.2.12 Battery must be mounted with all components as shown in the illustration either like version 1 (below left) or like version 2 (below right).

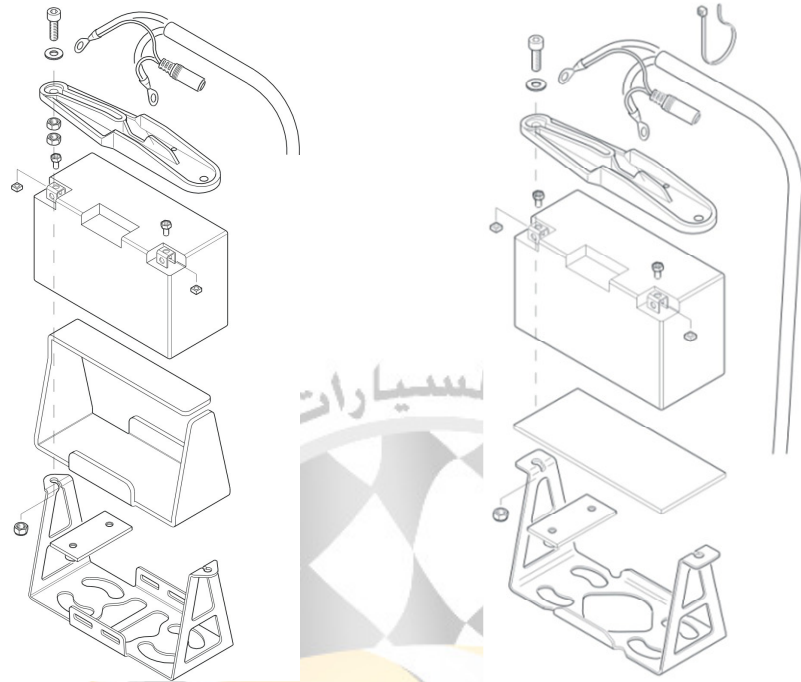

11.3 Exhaust Valve (125 MAX only)

11.3.1 As supplied by the manufacturer with no modification allowed. Compression spring (part number 239942, length 42.5mm) must be fitted.

11.3.2 Length of the exhaust valve is 36.5 mm $+0.20$ mm/ -0.30 mm.

11.3.3 Width of collar is 4.8 mm ± 0.3 mm

11.3.4 Only the green coloured exhaust valve bellow is legal to be used (ROTAX part number 260723)

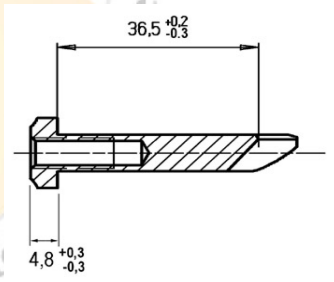

11.4 Centrifugal Clutch

11.4.1 Dry centrifugal clutch, engagement maximum at 4,000 rpm, i.e. the kart (without driver) must start to move before the maximum engine speed of 4,000 rpm.

There are two versions of the clutch shoe (element part # 3 on the diagram) and both are legal to be used. The older version of the clutch shoe can be either untreated or nitrated configuration.

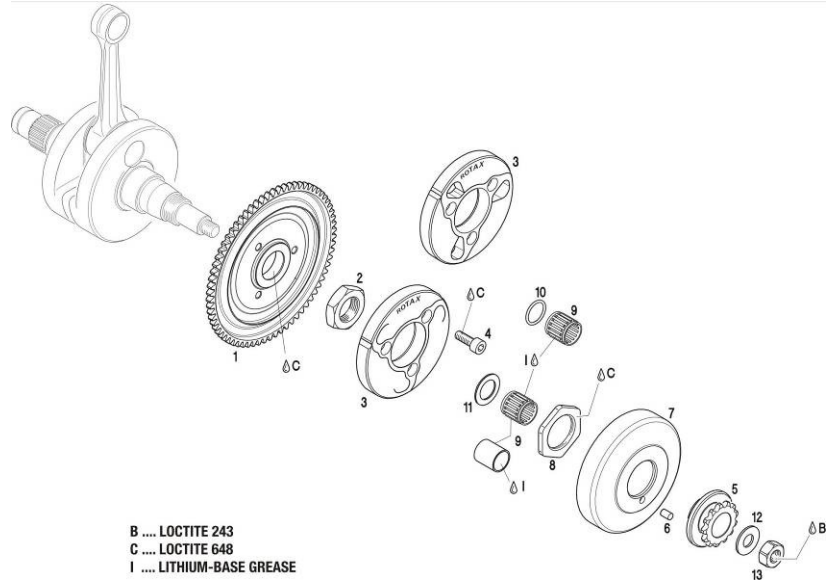

11.4.2 Engines must be fitted with new needle cage bearing 15x19x17 (item 9) as well as new O-Ring 12x2.5 (item 10) EXCEPT if the plain bearing 15x17x20 (item 9) designed for 11 teeth sprocket is used (in this case no O-ring may be used). No extra lubrication or additional substance is allowed inside the clutch drum in addition to the grease that originates from lubrication of the needle cage bearing and enters the clutch area.

The picture shows worst case scenario in case grease exits the bearing area even if the O-Ring is installed. Only the fixation nut as well as inside of drum show signs of grease but the running surface of the clutch is completely dry.

In case the plain bearing for 11 teeth sprocket is used clutch area must be absolutely free from grease or any additional substance.

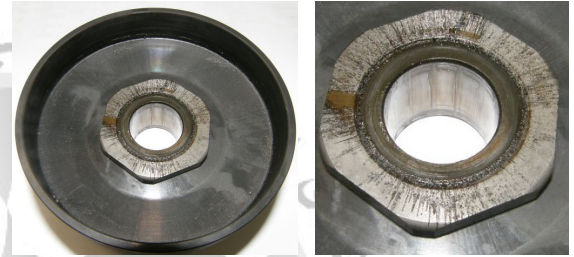

11.4.3 Steel clutch (both versions) and clutch drum must be within following specifications:

11.4.3.1 Minimum height of clutch **11.45mm** (picture below left)

11.4.3.2 Minimum thickness of clutch shoe **24.10mm** (picture far right).

Measurement must be done at the 3 open ends of the clutch shoes, 5-10 mm from the machined groove. All clutch shoes must be completely closed.



11.4.3.3 Minimum outer diameter of clutch drum **89.50mm** (picture below left). Diameter must be measured with a sliding calliper just beside the radius from the shoulder (not at the open end of the clutch drum).

11.4.3.4 Maximum inner diameter of clutch drum **84.90mm** (picture far right).

The inner diameter must be measured with a sliding calliper. The measurement must be taken in the middle of the clutch drum (in the contact area of the drum).



11.4.3.5 Minimum height of sprocket with clutch drum assembly 33.90mm (picture right).



11.5 Intake Silencer

11.5.1 Version 1 (below left) or version 2 (below right) of intake silencer with integrated, washable air filter must be used with all parts as shown in illustrations and must be mounted on the support bracket with two screws (in dry and wet race condition).

Intake silencer tube (version 2, position 2 below) as well as carburettor socket (version 2, position 6) are only legal if marked with "ROTAX".

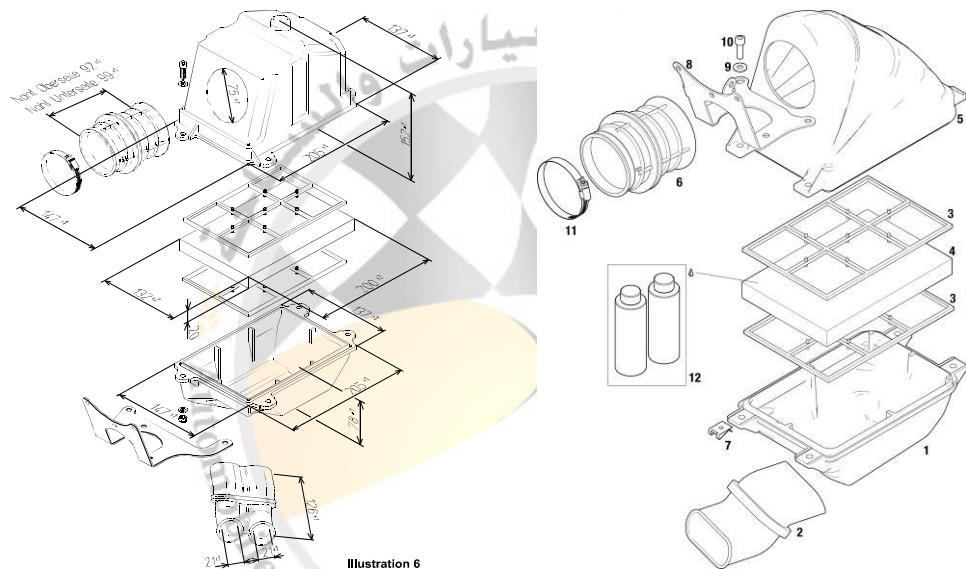

11.5.2 For version 1 it is allowed to drill one hole with 8 mm diameter in the lower part of the intake silencer (in the centre of the plastic injection mark) to automatically drain the intake silencer in case of heavy rain. This hole may stay unsealed also in dry conditions.

11.5.3 On version 2 the intake silencer case bottom is marked on the inside with ROTAX part no. 225015.

11.5.4 On version 2 the intake silencer case top is marked on the inside with ROTAX part no. 225025.

11.5.5 Air filter must be installed as shown in illustrations above.

11.6 Carburettor

11.6.1 DELL'ORTO carburettor

11.6.2 VHSB 34" cast in the housing of the carburettor.

11.6.3 "QD" or "QS" stamped in the housing of the carburettor.

11.6.4 Needle jet stamped with "FN 266"

11.6.5 The complete inlet bore in the casing of the carburettor must show cast surface

11.6.6 The carburettor slide must show size "40" in casting and the bottom end of the slide must show a cast surface.

11.6.7 Jet needle stamped with "K98" only

11.6.8 The following two combination of floats and idle jets are legal:

11.6.8.1 Combination 1:
Floats are marked with "gr 5.2"
Idle jet is stamped "30"
Idle jet insert is stamped "30"
Carb insert is 12.5 (see diagram)

11.6.8.2 Combination 2:
Floats are marked with "gr 3.6"
Idle jet is stamped "60"
Idle jet insert is stamped "60"
Carb insert is 8.5 (see diagram)

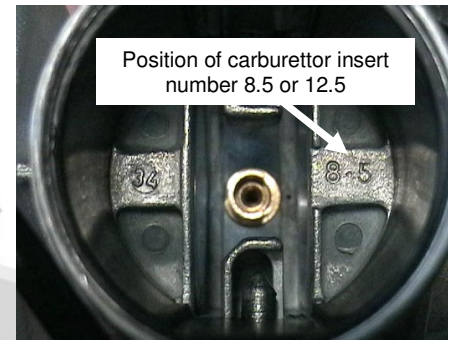

11.6.9 Needle valve is stamped "150"

11.6.10 Start jet is stamped with the digits "60"

11.6.11 Settings of the carburettor adjustment screws are free.

11.6.12 Main jets smaller than 158 are not permitted in the UAE RMC.
Note: main jets smaller than size 160 or bigger than 200 are not recommended by ROTAX (except in high altitude conditions)

11.6.13 Optional carburettor plug screw (ROTAX part no. 261030) is legal to be used.

11.7 Fuel Pump

MIKUNI diaphragm pump must be mounted on the support bracket (on the bottom or sideways) of the intake silencer.

11.8 Fuel Filter

The original fuel filter versions only (below pictures) are allowed to be fitted between the fuel tank and the fuel pump.



No additional parts except the fuel line, fuel pump as well as the original fuel filter are legal to be mounted between the fuel tank and the carburettor.

11.9 Radiator

11.9.1 Single aluminium radiator as shown in illustrations.
Name "ROTAX" stamped in the side of version 3.

11.9.2 Cooling area:
Version 1 & 2: height = 290 mm, width = 133 mm
Version 3: height = 290 mm, width = 138 mm

11.9.3 Thickness of radiator:
Version 1 & 2 = 32 mm
Version 3 = 34 mm

11.9.4 Place of fixing the radiator is on right side of engine.

11.9.5 Radiator must be mounted with all components as shown in the illustrations either like version 1, version 2 or version 3.

11.9.6 For version 2 there are 2 legal options to mount the radiator to the retaining plate (see drawing for details). For version 2 there are 2 different radiators with 2 different positions of the retaining plates (either pointing forward or backwards).

11.9.7 No additional non-original cooling device is allowed.
For versions 1 and 2 tape applied around the radiator is the only allowed air flow control. Tape may not be removed from the radiator during operation on the track. All other means of air flow control through the radiator are prohibited.
For version 3 the original plastic flap is the only way to control the airflow. Removal of the original plastic flap and use of tape, like for the version 1 and 2 of the radiator, is an acceptable configuration.

11.9.8 The removal of the thermostat from the cylinder head cover is an acceptable configuration.

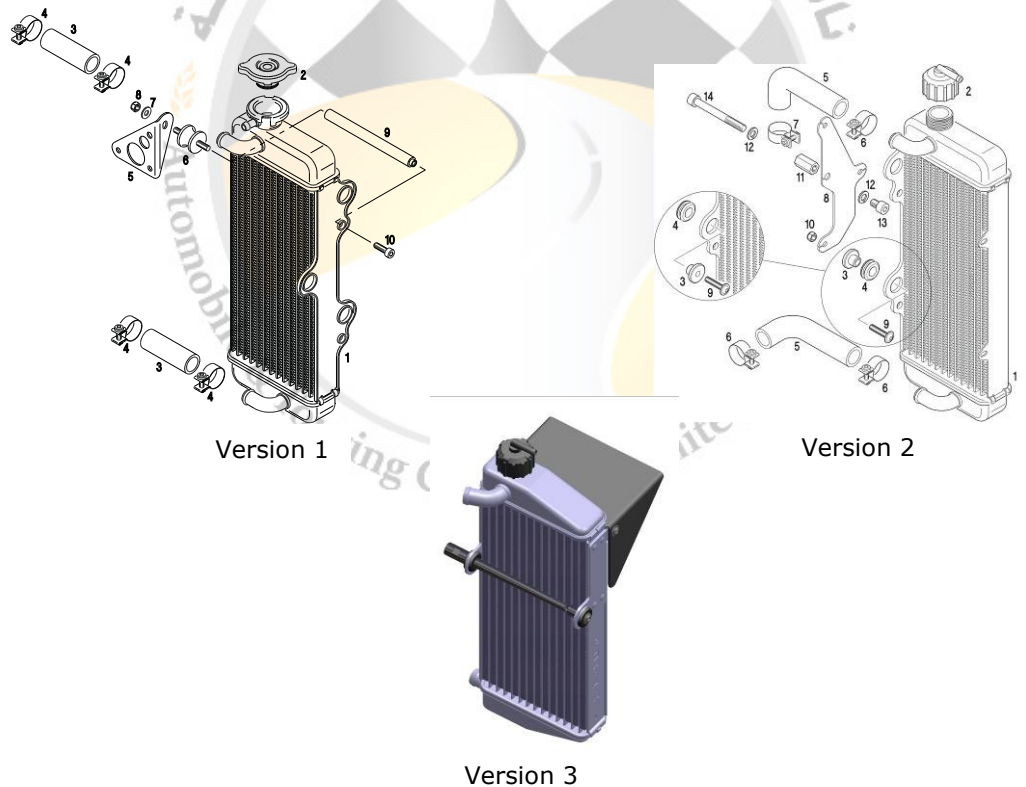

11.10 Radiator Coolant

As glycol coolants are prohibited, plain water without any additives has to be used.

11.11 Exhaust System

11.11.1 Must be as supplied by ROTAX and cannot be modified except for the replacement of the silencer absorption material and the use of threaded fasteners in place of rivets for securing the silencer end cap.

11.11.2 Standard exhaust socket must be used.

11.11.3 Exhaust pipe with after-muffler as shown in illustrations. Both versions (old with welded on after-muffler and new with after-muffler fixed by 2 springs) are legal to be used.

11.11.4 Maximum diameter of hole of end cap (pos 6, illustration) 21.0 mm.

11.11.5 Length of inlet cone 592mm +/-5 mm (measured on outside from beginning of exhaust pipe until beginning of cylindrical part).

11.11.6 Length of cylindrical part of exhaust pipe: 125 mm +/-5 mm.

11.11.7 Length of end cone 225mm +/-5 mm

11.11.8 Outside diameter of 180° bent tube 41mm +1.5 mm/-1.0 mm (measured at beginning and end of bend).

11.11.9 Just one piece of original isolating mat is allowed to be used. The original exhaust system (tuned pipe and silencer) may not be modified, except for the addition of extra elements for further noise reduction.

11.11.10 For measuring the exhaust gas temperature it is allowed to weld a socket on top of the exhaust, 50 mm from the ball joint.

11.11.11 The use of a maximum 4 pieces of original ROTAX exhaust springs to fix the exhaust to the cylinder is allowed (no safety wire allowed in exhaust flange area).

11.11.12 Unpainted exhaust system as delivered in first years of production is not legal to be used.

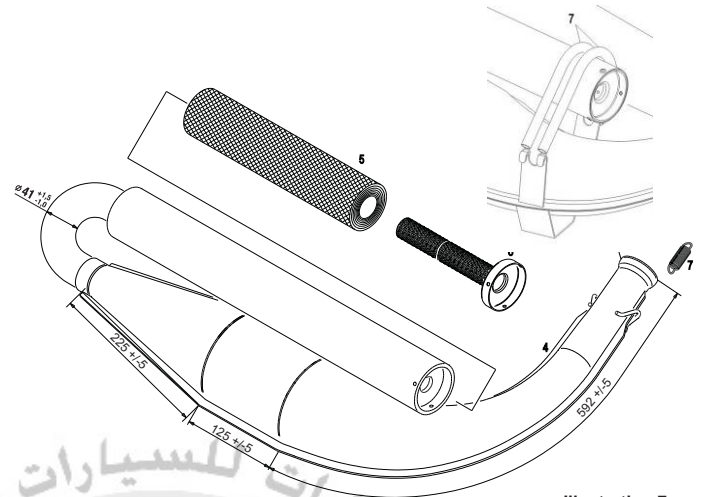

Illustration 7

11.12 Noise Emissions

11.12.1 Noise isolating mat (see illustration exhaust system) must be replaced by an original ROTAX spare part if noise emission is exceeding 92 dB (A).

11.12.2 Noise emission measuring procedure:

At a section of the track where the engine is operated under full load at rpm range of 11-12,000.

Microphone must be installed 1 metre above the level of the track at a perpendicular angle to the track.

The distance between the microphone and the kart on the ideal line on the track should be 7.5 metres. The kart should be operated under full load on the ideal line on the circuit.

12 – TECHNICAL SPECIFICATION (WITHIN ENGINE SEAL) FOR ROTAX KART ENGINE 125 MAX DD2 (24 kW)

12.1 Squish Gap

125 MAX DD2 1.00 - 1.50 mm

The squish gap must be measured with a certified slide gauge and by using a 2 mm tin wire. The crankshaft must be turned by hand slowly over TDC (top dead centre) to squeeze the tin wire.

The squish gap must be measured on the left and right side in the direction of the piston pin. The average value of the two measurements counts.

12.2 Combustion Chamber Insert

12.2.1 Cast identification code must be "223 389," "223 389 1," "223 389 2" or "223 389 2/1"

12.2.2 Cast wording "ROTAX" and/or "MADE IN AUSTRIA" must be shown.



12.2.3 Heights of combustion chamber insert must be 27.55 mm with a tolerance of +0.0/-0.1 mm (A) and 28.80 mm with a tolerance of +/- 0.2 mm (B).

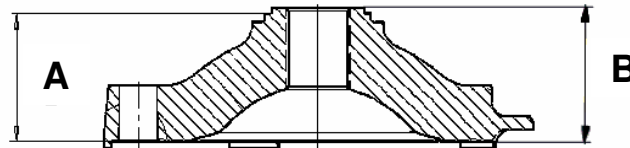

12.2.4 The profile of the combustion chamber insert has to be checked with a template (ROTAX part no. 277 390).

The crack of light between the template and the profile of the combustion chamber insert must be the same over the whole profile.

NOTE: This check is just for reference. In case of doubt detailed measurements must be performed to define conformity or non-conformity.



12.3 Piston with ring assembly

12.3.1 Original, coated or uncoated, aluminium, cast piston with one piston ring. The piston has to show on the inside the cast wording "ELKO" (1) and "MADE IN AUSTRIA" (2).

12.3.2 Machined areas are: top end of piston, outside diameter, groove for the piston ring, bore for the piston pin, inside diameter at bottom end of piston and some pre-existing factory removal (3) of flashing at the cut out of the piston skirt. All other surfaces are not machined and have cast surface.

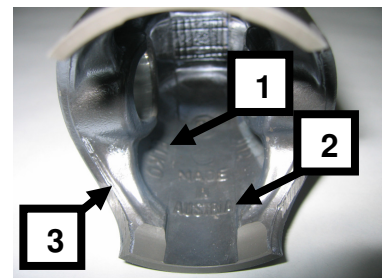

12.3.3 Original, magnetic, rectangular piston ring.
 Ring height: 1 -0.01 / -0.025 mm.
 Piston ring is marked either with "E CRY K" or "ROTAX 215 547" or "ROTAX 215 548".

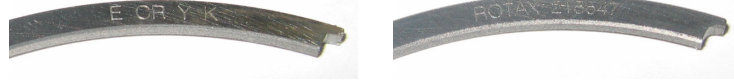

12.4 Gudgeon pin

- 12.4.1** Gudgeon pin is made out of magnetic steel.
- 12.4.2** Dimensions must be according to the drawing.
- 12.4.3** The minimum weight of the gudgeon pin must not be lower than 32.10g

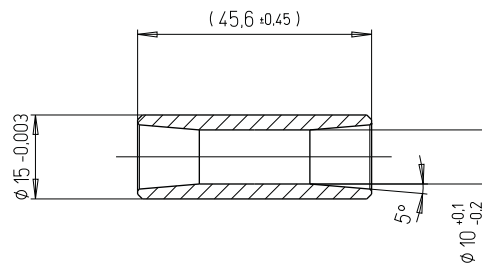

12.5 Cylinder

- 12.5.1** Light-alloy-cylinder with GILNISIL-plating. Any re-plating of cylinder is not allowed.
- 12.5.2** Cylinder with one main exhaust port and two side exhaust ports.
- 12.5.3** Maximum bore of cylinder = 54.035mm (measured 10mm above exhaust port)
- 12.5.4** Cylinder must be marked with the "ROTAX" logo (see pictures below).
- 12.5.5** Cylinder with pneumatic timed exhaust valve. Cylinder must be marked either with identification code 613930, 613931 or 613933.



12.5.6 Height of cylinder must be 86.7mm -0.05/+0.1 mm (see right picture).



12.5.7.1 All transfer ports and passages have cast finish surface except some removal (done by the manufacturer) of cast burr at the inlet passage and exhaust port and passages. All ports have chamfered edges to prevent ring snagging. Any additional machining is not permitted. The top edge of exhaust port may show some pre-existing machining from the manufacturer. The sealing flange for the exhaust socket may show signs of machining from the manufacturer.



12.5.7.2 All ports have chamfered edges (see below right picture). Any additional machining is not permitted.

On cylinder marked 613933 the upper edge of the central boost port may show factory machining (see adjacent picture)

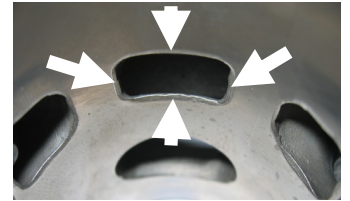
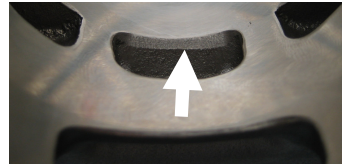

12.5.7.3 The sealing flange for the exhaust socket may show either cast finish surface or signs of machining from the manufacturer.

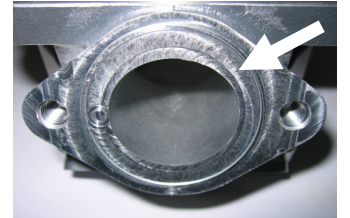

12.5.7.4 The top edge of the exhaust port may show either just a cast finish surface (below left picture) or signs of a CNC machining (below centre picture) or signs of CNC machining in combination with signs of manual grinding (below right picture).

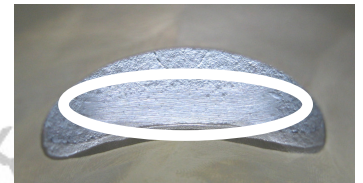
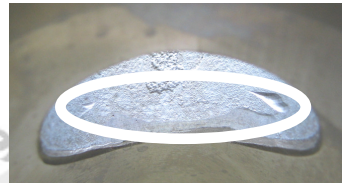
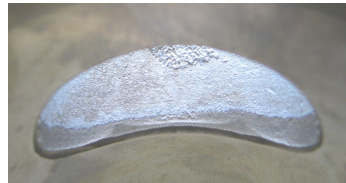

The exhaust port may show partial manual grinding done by the manufacturer to eliminate minor casting defects and to eliminate the NIKASIL burr at the end of the NIKASIL plating.

The exhaust ports of cylinder 613933 may show factory machining all around (see right picture).



12.5.8 The "exhaust port timing" (distance from the top of the cylinder to the top of the exhaust port) must be checked by means of the template (ROTAX part 277397).

Insert the template into the cylinder so that the template is touching the cylinder wall and the finger of the template is located in the middle of the exhaust port (highest point).

Move the template upwards until the finger is touching the top edge of the exhaust port. Insert a feeler gauge between the top of the cylinder and the template. It MUST NOT be possible to fit the feeler gauge specified below:

125 MAX DD2: 0.75 mm

For cylinder 613933 it is also legal if the template does not fit in at all.



NOTE: Take care to use the corresponding gauge of the template (DD2) for the respective cylinder!

12.5.9 Exhaust Valve

If the piston is moved to the top of the cylinder until is completely covers the exhaust port, it must be possible to insert the exhaust valve gauge (ROTAX part 277030) until it stops at the surface of the cylinder (a feeler gauge of 0.05 mm must not be possible to fit in).

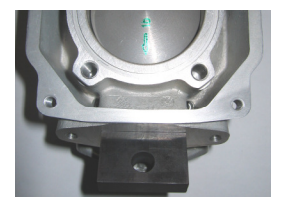

12.6 Inlet System

12.6.1 Inlet manifold is marked with the name "ROTAX" and the identification code "267 410".

12.6.2 Some factory flash removal may be present at the conjunction of the inside contour and the carburettor stop mounting face. This is a manual trimming operation consisting of a small corner break of less than 3 mm in width. No additional grinding or machining is permitted.

12.6.3 The reed valve assembly is equipped with 2 petal stops and 2 reeds, each having 3 petals.

12.6.4 The thickness of the reeds is 0.6 mm +/- 0.10 mm.

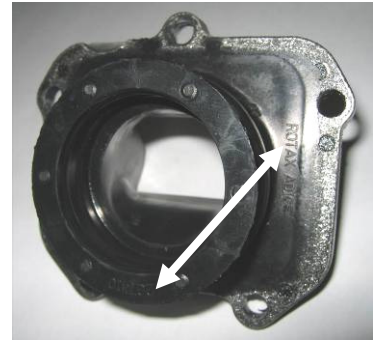

12.7 Crankshaft

12.7.1 Stroke 54.5 mm +/-0.1 mm

12.7.2 Con rod has to show forged numbers "213", "365" or "367" on shaft.

12.7.3 Shaft of con rod is not machined (copper plated). Grinding or polishing of shaft of con rod is not permitted.

12.7.4 Crankshaft main bearing 6206 from FAG only is allowed (must be marked with code **579165BA** or **Z-579165.11.KL**)

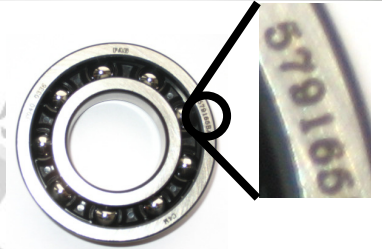

12.8 2-Speed Gearbox

12.8.1 Primary shaft with 19 teeth for 1st gear and 24 teeth for 2nd gear.

12.8.2 Idle gear for 1st gear must have 81 teeth.

12.8.3 Idle gear for 2nd gear must have 77 teeth.

12.9 Crankcase

As supplied by the manufacturer. No grinding/polishing is permitted in the two main transfer passages as well as in the crank area.

13 – TECHNICAL SPECIFICATION (OUTSIDE ENGINE SEAL) FOR ROTAX KART ENGINE 125 MAX DD2 (24 kW)

It is the responsibility of the competitor to check all components outside the engine seal to ensure that they are in line with the technical specifications below.

13.1 Ignition System

13.1.1 DENSO digital battery ignition, variable ignition timing, no adjustment necessary and possible.

Race officials may request at any time that the competitor replace the ignition coil with a new unit provided by the race administration.

13.1.2 The casting of the ignition coil has to show the following in casting "129000-" and "DENSO".

13.1.3 Ignition coil must show 4 or 6 pins at the terminal.

13.1.4 Connector housing of ignition coil must have either white or grey colour.

13.1.5 The ignition coil has to be fixed by means of 2 original silent blocks to the crankcase. Only in case of chassis component interference with the original mounting location of the ignition coil, a supplementary extension bracket, rigidly constructed and fabricated of solid metal, of minimum dimensions and attached to the original case mounting holes, is permitted for mounting of the coil.

13.1.6 The minimum length of ignition wire (high tension wire) is 210 mm from outlet of cable at ignition coil to outlet of cable at spark plug connector (= the visible length of wire). Ignition coil must be in working condition (to be tested in case of doubt).

13.1.7 The pick-up must be marked with the numbers 029600-0710, followed by a variable production code in the 2nd line.

HINT: In case of doubt an easy check is to place a steel ball (3-5 mm in diameter) on the pick-up (engine side). The steel ball must stay in the centre of the pickup surface.

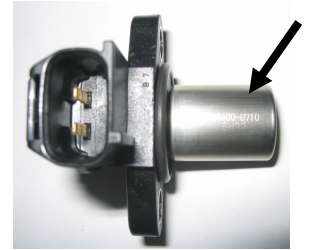

13.1.8 Spark plug: DENSO Iridium IW 27 or 29 or 31

13.1.9 Spark plug cap must be marked with "NGK TB05EMA".

13.1.10 Original battery must be used:
YUASA YT7B-BS or **ROTAX** RX7-12B or **ROTAX** RX7-12L (lithium iron phosphate)

13.1.11 Battery must be fitted with the original battery clamp and battery cover (see illustration below) and must be fixed to the chassis with at least 2 screws. Position of the battery is free.

13.1.12 Battery must be mounted with all components as shown in the illustration either like version 1 (below left) or like version 2 (below right).

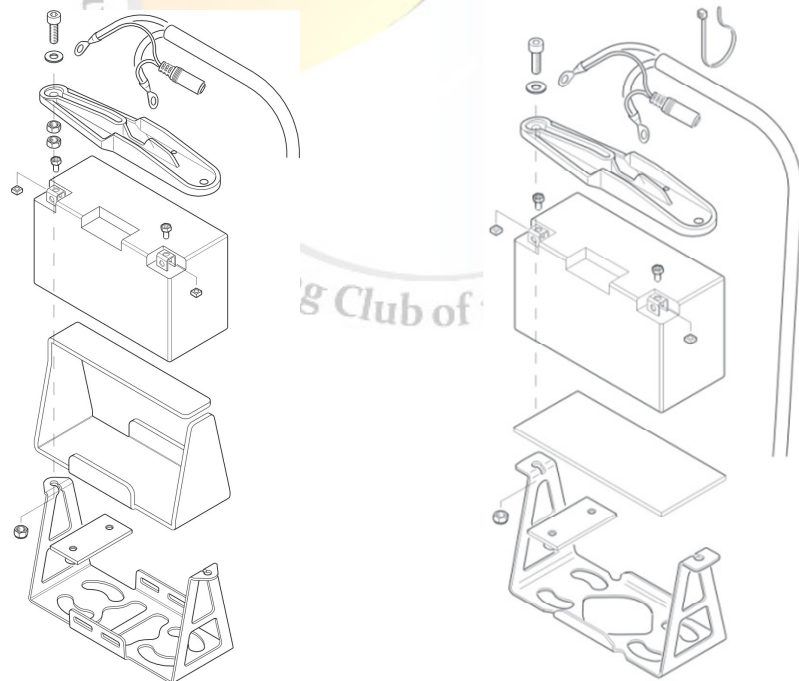

13.2 Exhaust Valve

13.2.1 As supplied by the manufacturer with no modification allowed. Compression spring (part number 239950, length 48.5mm) must be fitted.

13.2.2 Length of the exhaust valve is 36.5 mm +0.20 mm/-0.30 mm.

13.2.3 Width of collar is 4.8 mm +/-0.3 mm

13.2.4 Only the green coloured exhaust valve bellow is legal to be used (ROTAX part number 260723)

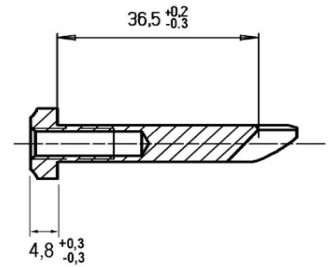

13.3 Balance Drive

13.3.1 Balance drive gear must be fitted on crank shaft.

13.3.2 Balance gear must be fitted on primary shaft and must be aligned with the balance drive gear according to the instruction in the repair manual.

13.3.3 Fly weight of old version balance gear must show cast surface (see above picture).

13.3.4 Fly weight of new version balance gear can show machined surface (right picture).

13.3.5 Dimension A (widest part of balance weight) must be either 53 mm +/- 0.5mm or 57 mm +/- 0.5mm

13.3.6 The minimum weight of a dry balance gear including bearing (new version only) must not be lower than 240g.

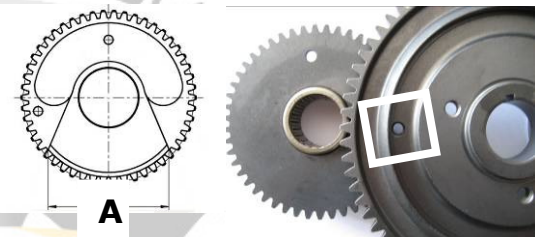

13.4 Centrifugal Clutch

13.4.1 Dry centrifugal clutch, engagement maximum at 4,000 rpm, i.e. the kart (without driver) must start to move before the maximum engine speed of 4,000 rpm. Both clutch element versions as in illustration are legal to be used. Old version clutch element can be either untreated or nitrated configuration.

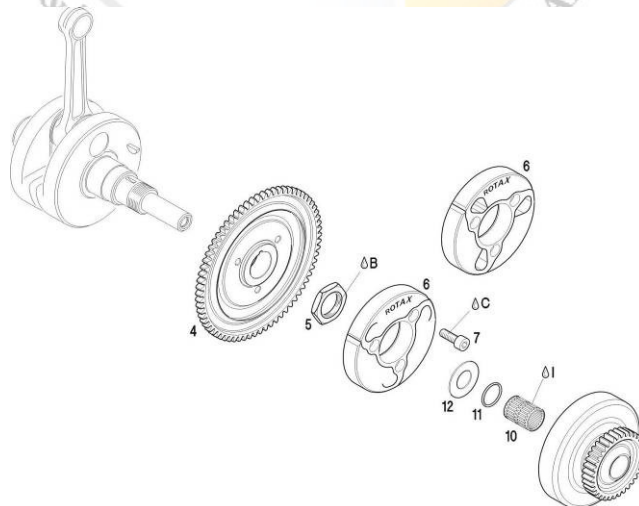

13.4.2 Steel clutch (both versions) and clutch drum must be within following specifications:

13.4.2.1 Minimum height of clutch 14.45mm (picture below left)

13.4.2.2 Minimum thickness of clutch shoe 24.10mm (picture far right).

Measurement must be done at the 3 open ends of the clutch shoes, 5-10 mm from the machined groove. All clutch shoes must be completely closed.



13.4.2.3 Minimum outer diameter of clutch drum 89.50mm (picture below left). Diameter must be measured with a sliding calliper just beside the radius from the shoulder (not at the open end of the clutch drum).

13.4.2.4 Maximum inner diameter of clutch drum 84.90mm (picture far right).

The inner diameter must be measured with a sliding calliper. The measurement must be taken in the middle of the clutch drum (in the contact area).



13.4.2.5 Minimum height of sprocket with clutch drum assembly 39.50mm (picture right).



13.5 Primary Drive

13.5.1 Original primary drive gears of following gear ratio options must be used. Only mentioned pairs are legal to be used:

Drive gear	Driven gear
33	64
34	63
35	62
36	61
37	60

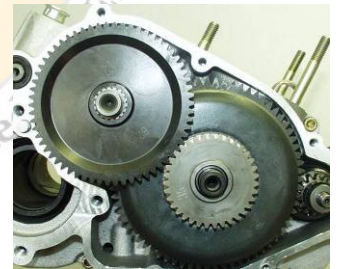

13.5.2 A specific primary gear ratio may be determined for each race event by a "Supplementary Regulation".

13.6 Gear Shifting

13.6.1 The 2-speed gearbox has to be operated with one of the 2 available original supplied shift paddle configurations on the steering wheel via the two Bowden cables.

13.6.2 For plastic paddle (version 1) only, the cutting of the original shift paddle or the adding of pads to the shift paddle in order to adjust the paddle to specific steering wheels is permitted.
For the aluminium paddle (version 2) no cutting or adding of non-original parts or material is allowed.

13.6.3 For plastic paddle only, the original hub for the steering wheel must be used.

Version 1 (plastic paddle):

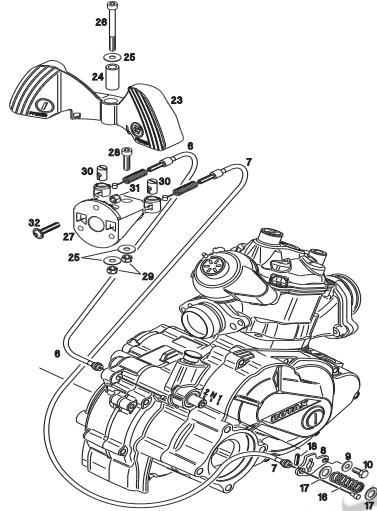

Version 2 (aluminium paddle):

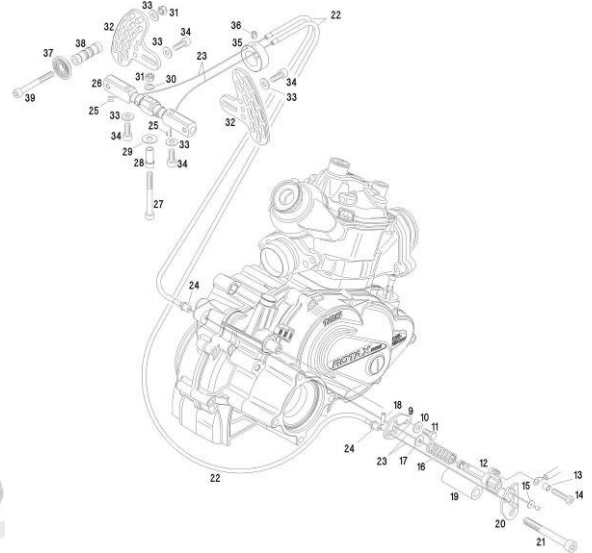

13.7 Intake Silencer

13.7.1 Intake silencer with integrated, washable air filter as shown in illustrations below (2 legal versions available).

13.7.2 The intake silencer case is marked on the inside with ROTAX part no. 225012.

13.7.3 The intake silencer cover is marked on the inside with ROTAX part no. 225022.

13.7.4 The air filter is marked with ROTAX part no. 225 052.

13.7.5 The air filter must be assembled between the intake silencer case and the intake silencer cover so that the whole area of the intake silencer case is covered.

13.7.6 In case of a wet race it is allowed to seal the top of the airbox using adhesive tape.

Version 1 (without o-ring):

Version 2 (with o-ring):

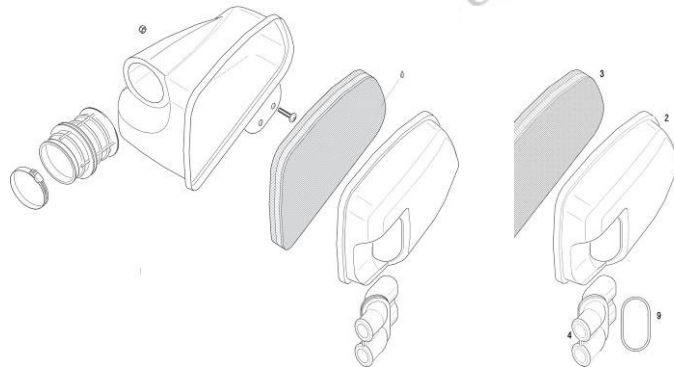

NOTE: Intake silencer tube and carb socket are only legal if marked "ROTAX".

13.8 Carburettor

13.8.1 DELL'ORTO carburettor

13.8.2 VHSB 34" cast in the housing of the carburettor.

13.8.3 "QD" or "QS" stamped in the housing of the carburettor.

13.8.4 Needle jet stamped with "FN 266"

13.8.5 The complete inlet bore in the casing of the carburettor must show cast surface

13.8.6 The carburettor slide must show size "40" in casting and the bottom end of the slide must show a cast surface.

13.8.7 Jet needle stamped with "K98"

13.8.8 The following two combination of floats and idle jets are legal:

13.8.8.1 Combination 1:
Floats are marked with "gr 5.2"
Idle jet is stamped "30"
Idle jet insert is stamped "30"
Carb insert is 12.5 (see diagram)

13.8.8.2 Combination 2:
Floats are marked with "gr 3.6"
Idle jet is stamped "60"
Idle jet insert is stamped "60"
Carb insert is 8.5 (see diagram)

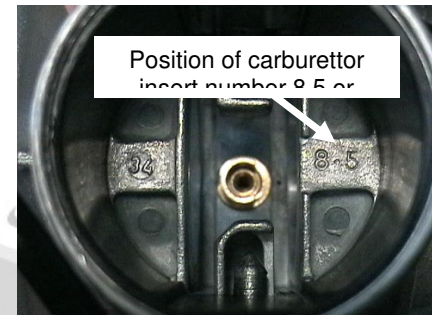

13.8.9 Needle valve is stamped either "150" or "200"

13.8.10 Start jet is stamped with the digits "60"

13.8.11 Settings of the carburettor adjustment screws are free.

13.8.12 Main jets smaller than 175 are not permitted in the UAE RMC.
Note: main jets smaller than size 175 or bigger than 205 are not recommended by ROTAX (except in high altitude conditions)

11.6.13 Optional carburettor plug screw (ROTAX part no. 261030) is legal to be used.

13.9 Fuel Pump

13.9.1 Original diaphragm fuel pump (grey or black colour) must be fitted by means of two original silent blocks to the chassis or the engine. Optionally the MIKUNI diaphragm pump (as used on 125 MAX engine) can be used.

13.9.2 Centreline of fuel pump may not be higher than the centreline of carburettor.

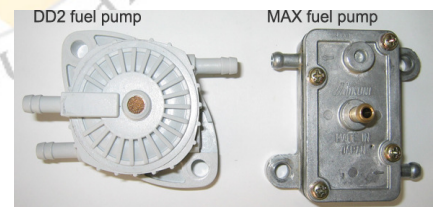

13.10 Fuel Filter

The original fuel filter versions only (pictures right) are allowed to be fitted between the fuel tank and the fuel pump.

No additional parts except the fuel line, fuel pump as well as the original fuel filter are legal to be mounted between the fuel tank and the carburettor.



13.11 Radiator

13.11.1 Single aluminium radiator (see illustrations)

13.11.2 "ROTAX" stamped on top/side of radiator.

13.11.3 Cooling area:

Version 1: height = 284 mm, width = 202 mm

Version 2: height = 290 mm, width = 196 mm

13.11.4 Radiator thickness (version 1) = 32 mm

Radiator thickness (version 2) = 34 mm

13.11.5 The radiator should be mounted on left side of kart beside the seat.

13.11.6 The highest point of the radiator with cap may not be higher than 400 mm above the main tube of the kart chassis.

13.11.7 No additional non-original cooling device is allowed. For version 1 tape applied around the radiator is the only allowed air flow control. Tape may not be removed from the radiator during operation on the track. All other means of air flow control through the radiator are prohibited.

For version 2 the original plastic flap is the only way to control the airflow. Removal of the original plastic flap and use of tape (like version 1 of the radiator) is an acceptable configuration.

13.11.8 The removal of the thermostat from the cylinder head cover is an acceptable configuration.

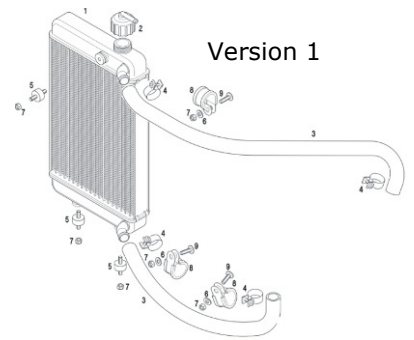

Version 1



13.12 Radiator Coolant

As glycol coolants are prohibited, plain water without any additives must be used.

13.13 Exhaust System

13.13.1 Must be as supplied by BRP-Powertrain and cannot be modified except for the replacement of the silencer absorption material and the use of threaded fasteners in place of rivets for securing the silencer end cap.

13.13.2 Standard exhaust socket must be used.

13.13.3 Exhaust pipe with after-muffler as shown in illustrations. Both versions (old with welded on after-muffler and new with after-muffler fixed by 2 springs) are legal to be used.

13.13.4 Diameter of hole of end cap of (pos 5, illustration): 19.6 mm +/-0.2 mm.

13.13.5 Just one piece of original isolating mat is allowed to be used.

13.13.6 The original exhaust system (tuned pipe and silencer) may not be modified, except for the addition of extra elements for further noise reduction.

13.13.7 For measuring the exhaust gas temperature, it is allowed to weld a socket on to the exhaust in an area 50-80 mm from the ball joint.

13.13.8 The use of maximum 4 pieces of original ROTAX exhaust springs to fix the exhaust to the cylinder is allowed (no safety wire allowed in exhaust flange area).

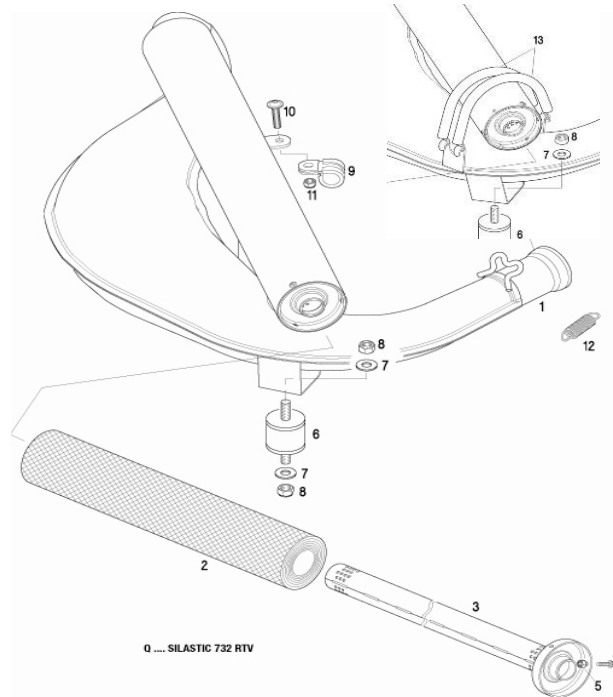

13.14 Noise Emissions

13.14.1 Noise isolating mat (see illustration exhaust system) must be replaced by an original BRP-Powertrain spare part if noise emission is exceeding 92 dB (A).

13.14.2 Noise emission measuring procedure:

At a section of the track where the engine is operated under full load at rpm range of 11-12,000.

Microphone must be installed 1 metre above the level of the track at a perpendicular angle to the track.

The distance between the microphone and the kart on the ideal line on the track should be 7.5 metres. The kart should be operated under full load on the ideal line on the circuit.

UAE ROTAX MAX CHALLENGE 2012-13 TECHNICAL REGULATIONS

APPENDIX FOR 125 MINI MAX AND 125 MICRO MAX VERSION 01.09.12

A1 – TECHNICAL SPECIFICATION (WITHIN ENGINE SEAL) FOR ROTAX KART ENGINE 125 MINI MAX (10 kW) AND 125 MICRO MAX (5 kW)

Please note that for engine configuration 125 Micro MAX and 125 Mini MAX, the technical specification of 125 Junior MAX is valid for anything unspecified below.

A1.1 Squish Gap

The squish gap must be measured with a certified slide gauge and by using a 2 mm tin wire for 125 Mini MAX or 3 mm tin wire for 125 Micro MAX.

The crankshaft must be turned by hand slowly over TDC (top dead centre) to squeeze the tin wire. The squish gap must be measured on the left and right side in the direction of the piston pin. The average value of the two measurements counts.

Recommended 2mm tin wire (580 130); 3mm tin wire (580 132)

A1.1.1 125 Mini MAX 1.20 - 1.80 mm

A1.1.2 125 Micro MAX 2.40 - 2.70 mm

To achieve this defined squish gap, a spacer (ROTAX part number 626 420) with a thickness of 1.25mm must be used along with the different required base gaskets.

A2 – TECHNICAL SPECIFICATION (OUTSIDE ENGINE SEAL) FOR ROTAX KART ENGINE 125 MINI MAX (10 kW)

Please note that for engine configuration 125 Mini MAX, the technical specification of 125 Junior MAX is valid for anything unspecified below.

A2.1 Intake Restrictor

A2.1.1 The intake restrictor (ROTAX part number 267 535) must be fitted between the carburettor flange and the carburettor.

A2.1.2 The intake restrictor must show an inner diameter of 19.0 mm +0.0/-0.2mm.

A2.1.3 The intake restrictor can be either blue anodised or white Teflon.

A2.2 Exhaust Restrictor

A2.2.1 The exhaust restrictor (ROTAX part number 273 972) must be used instead of the original exhaust socket (fitted to cylinder).

A2.2.2 The exhaust restrictor must show an inner diameter of 22.0 mm ±0.2mm.

A2.3 Noise Emissions

A2.3.1 The noise isolating mat (see illustration 11.11) must be replaced by an original ROTAX spare part if the noise emission is exceeding 90 dB.

A2.3.2 Noise emission measuring procedure:

The measuring place must be at a section of the track where the engine is operated under full load at an engine speed range of 9,000 to 10,000 rpm.

A3 – TECHNICAL SPECIFICATION (OUTSIDE ENGINE SEAL) FOR ROTAX KART ENGINE 125 MICRO MAX (5 kW)

Please note that for engine configuration 125 Micro MAX, the technical specification of 125 Junior MAX is valid for anything unspecified below.

A3.1 Carburettor

A3.1.1 The spacer (pos 1 right, ROTAX part number 251 730) must be fitted in the carburettor to limit the opening of the throttle.

A3.1.2 The length of the spacer must be 38.0 mm \pm 0.2mm.

A3.1.3 The position of the cap of the carburettor must be fixed by means of the fixation plate (pos 1 in below picture, ROTAX part number 251 790).

A3.1.4 The cap of the carburettor must be screwed completely onto the carburettor.

A3.1.5 Only 1 rubber gasket is allowed to be used in the carburettor cap.

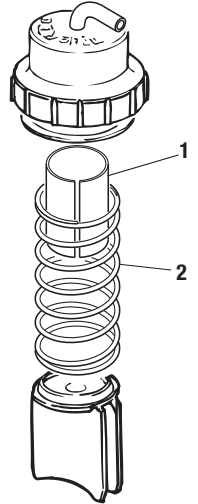
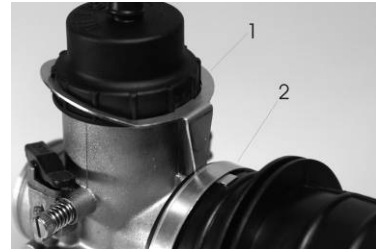

A3.2 Exhaust Restrictor

A3.2.1 The exhaust restrictor (ROTAX part number 273 972) must be used instead of the original exhaust socket (fitted to cylinder).

A3.2.2 The exhaust restrictor must show an inner diameter of 22.0 mm \pm 0.2mm.

A3.3 Radiator

A3.3.1 A specific Micro MAX radiator (ROTAX part number 295 924 or 295 923) must be used instead of the original radiator.

A3.3.2 Radiator must be mounted with all components similar to the illustration (see also 11.9 version 2 and 3 for 125 MAX engine).

A3.3.3 Cooling area:
Height = 280-300 mm; Width = 58-62 mm

A3.3.4 Thickness of radiator = 30-34 mm

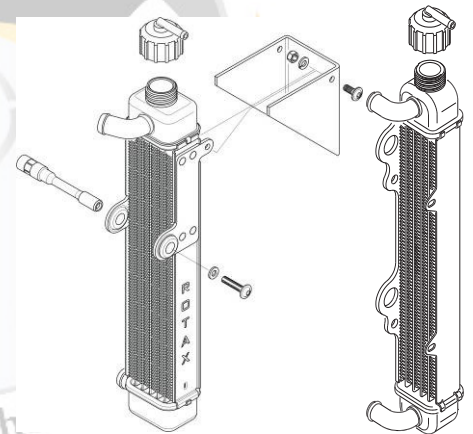

A3.4 Exhaust System

A3.4.1 The specific Micro MAX exhaust system must be used instead of the original exhaust system (see illustration).

A3.4.2 The inner diameter of the 90° tube at the end of the silencer must be 15.0mm \pm 0.3mm.

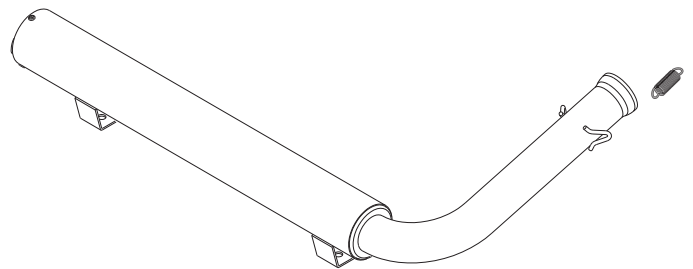

A3.4.3 In addition to the standard isolating mat a special steel isolating mat of square dimension 165mm +10mm must be assembled underneath the standard isolating mat as in the following picture (ROTAX part number 297 983). Clamp (1) is optional.

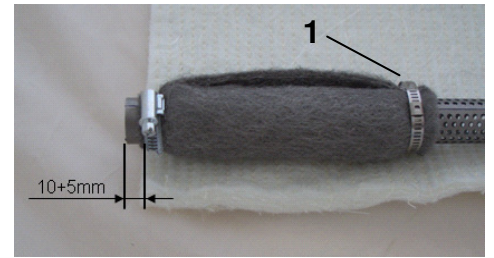

A3.5 Noise Emissions

A3.5.1 The noise isolating mat (see illustration 11.11) must be replaced by an original ROTAX spare part if the noise emission is exceeding 90 dB.

A3.5.2 Noise emission measuring procedure:

The measuring place must be at a section of the track where the engine is operated under full load at an engine speed range of 8,000 to 9,000 rpm.

The microphone must be installed 1 metre above the level of the track at a perpendicular angle to the track.

The distance between the microphone and the kart on the ideal line on the track should be 7.5 metres. The kart should be operated under full load on the ideal line on the circuit.

